

# Spare parts for CN cylinders

## 1 EXPLODED VIEW OF THE CYLINDER

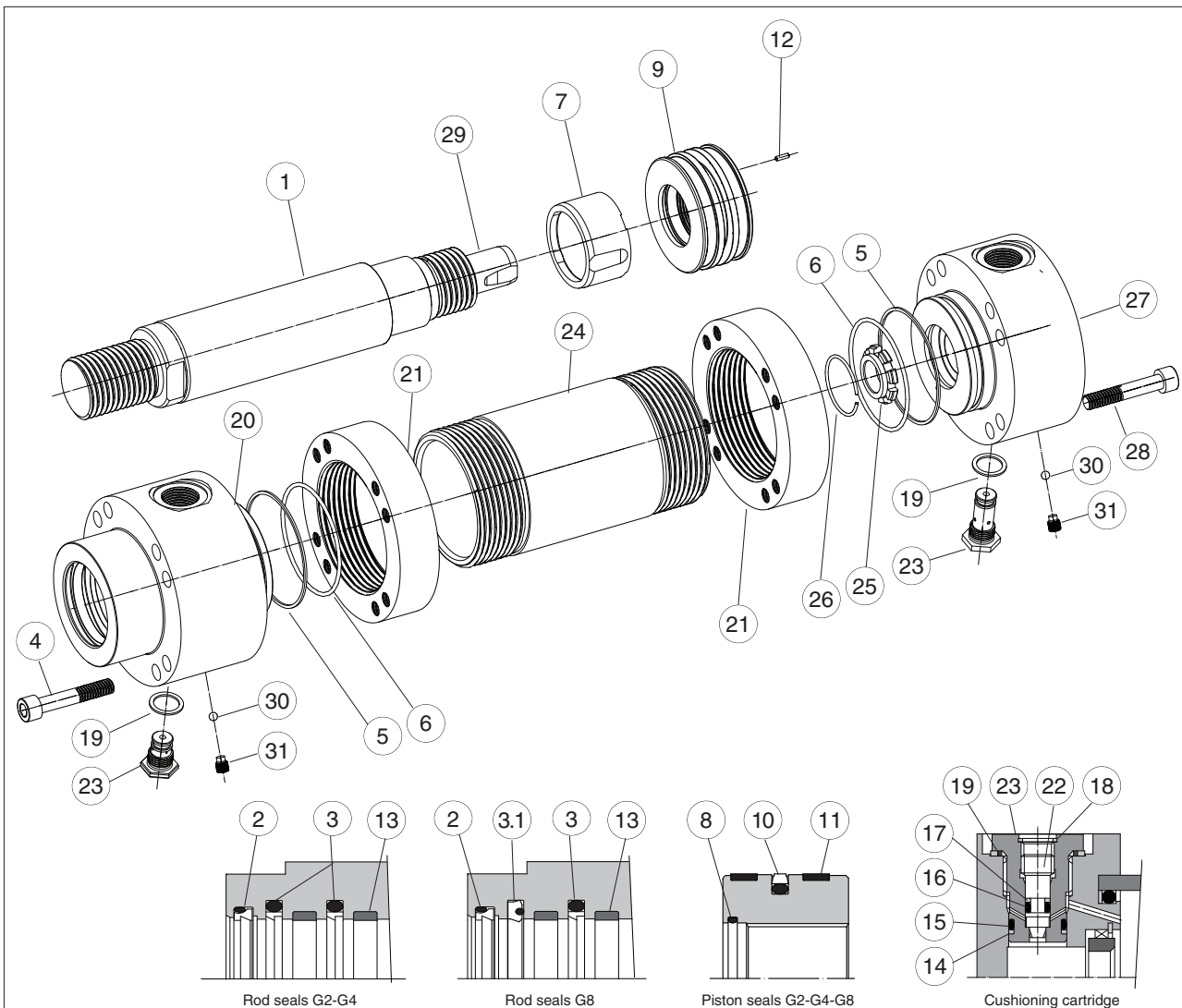

POS	DESCRIPTION	POS	DESCRIPTION
1	Rod	16	O-ring - cushioning screw
2	Wiper	17	Antiextrusion ring - cushioning screw
3	Rod seal - PTFE	18	Seeger
3.1	Rod seal - polyurethane	19	Bonded seal
4	Front Screw	20	Front head
5	Antiextrusion ring - cylinder housing	21	Counterflange
6	O-Ring - cylinder housing	22	Cushioning adjustment screw
7	Front cushioning piston	23	Cushioning adjustment cartridge
8	O-ring - piston	24	Cylinder housing
9	Piston	25	Cushioning sleeve - rear
10	Piston seal	26	Toroidal ring - rear
11	Piston wear rings - PTFE	27	Rear head
11.1	Piston wear rings - phenolic resin	28	Rear screw
12	Locking pin - piston/rod	29	Rear cushioning piston
13	Rod wear rings - synthetic resin	30	Steel sphere - air bleed
14	Antiextrusion ring - cushioning cartridge	31	Grub screw - air bleed
15	O-ring - cushioning cartridge	-	

#### 4 ASSEMBLING TOOLS

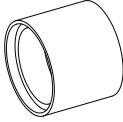
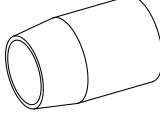
		SP - KP - XX BORE SIZE				SP - KR - XX ROD DIAMETER
						
ASSEMBLING OPERATION	CYLINDER SIZE	TOOL	TOOL DIMENSION	TORQUE [Nm]		
Cushioning adjustment cartridge (pos.23) assembling	Bores 40 - 200	Hexagonal wrench	22	19,6		
Screws (pos. 4-28) for heads assembling	Bores 40 - 200	Allen key	According to the bore size	See table B180 section [4]		
Grub Screw (pos. 31) for air bleed screwing	Bores 40 - 200	Allen key	4	6		
Calibration of piston seal	Bores 40 - 200	SP - KP - XX	According to the bore size	-		
Calibration of rod seals	Bores 40 - 200	SP - KR - XX	According to the rod diameter	-		

#### 5 SPARE PARTS CODES

##### 5.1 Seals

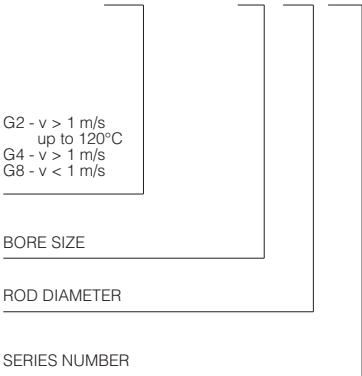
ORDER CODE	POS	DESCRIPTION	G8	G2	G4
<p style="text-align: center;"><b>SP - G8 - CN - 50 / 36 - 12</b></p>  <p>G2 - v &gt; 1 m/s up to 120°C G4 - v &gt; 1 m/s G8 - v &lt; 1 m/s</p>	2	Wiper - PTFE	•	•	•
	3	Rod seal - PTFE (ISO 7425)	•	• [2] (a)	• [2] (a)
	3.1	Rod seal - polyurethane (ISO 7425)	•		
	5	Antiextrusion ring - cylinder housing	• [2]	• [2]	• [2]
	6	O-ring - cylinder housing	• [2]	• [2]	• [2]
	8	O-ring - piston	•	•	•
	10	Piston seal - PTFE (ISO 7425)	•	•	•
	11	Piston wear rings - PTFE		• [2]	• [2]
	11.1	Piston wear rings - phenolic resin	• [2]		
	12	Locking pin - piston/rod	•	•	•
	13	Rod wear rings - synthetic resin (b)	• [2]	• [2]	• [2]
	14	Antiextrusion ring - cushioning cartridge	• [2]	• [2]	• [2]
	15	O-ring - cushioning cartridge	• [2]	• [2]	• [2]
	16	O-ring - cushioning screw	• [2]	• [2]	• [2]
	17	Antiextrusion ring - cushioning screw	• [2]	• [2]	• [2]
	19	Bonded seal	• [2]	• [2]	• [2]

##### Notes

(a) CN-40 is supplied with the secondary seal made of polyurethane

(b) CN-200 is supplied with nr. 3 rod wear rings

##### 5.2 Piston rod

ORDER CODE	POS	DESCRIPTION	G8	G2	G4
<p style="text-align: center;"><b>SP - U - CN - 50 / 36 x 0500-X30..</b></p> <p>COMPLETE CYLINDER CODE + SERIES NUMBER</p>	1	Rod	•	•	•
	7	Front cushioning piston (if selected)	•	•	•
	8	O-ring - piston	•	•	•
	9	Piston	•	•	•
	10	Piston seal - PTFE (ISO 7425)	•	•	•
	11	Piston wear rings - PTFE		• [2]	• [2]
	11.1	Piston wear rings - phenolic resin	• [2]		
	12	Locking pin - piston/rod	•	•	•
	29	Rear cushioning piston (if selected)	•	•	•

##### 5.3 Cushioning

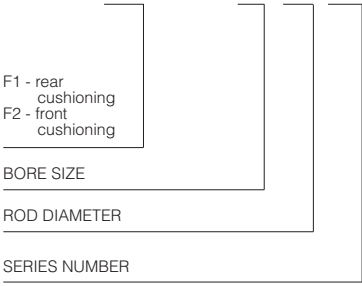
ORDER CODE	POS	DESCRIPTION	Front F2	Rear F1
<p style="text-align: center;"><b>SP - F1 - CN - 50 / 36 - 12</b></p>  <p>F1 - rear cushioning F2 - front cushioning</p>	7	Front cushioning piston	•	
	14	Antiextrusion ring - cushioning cartridge	•	•
	15	O-ring - cushioning cartridge	•	•
	16	O-ring - cushioning screw	•	•
	17	Antiextrusion ring - cushioning screw	•	•
	18	Seeger	•	•
	19	Bonded seal	•	•
	22	Cushioning adjustment screw	•	•
	23	Cushioning adjustment cartridge	•	•
	25	Cushioning sleeve - rear		•
	26	Toroidal ring - rear		•