

# Digital electronic drivers E-RI-AEG and controllers E-RI-AEZ

integral-to-valve format with cycle generator - for proportional directional valves without transducer

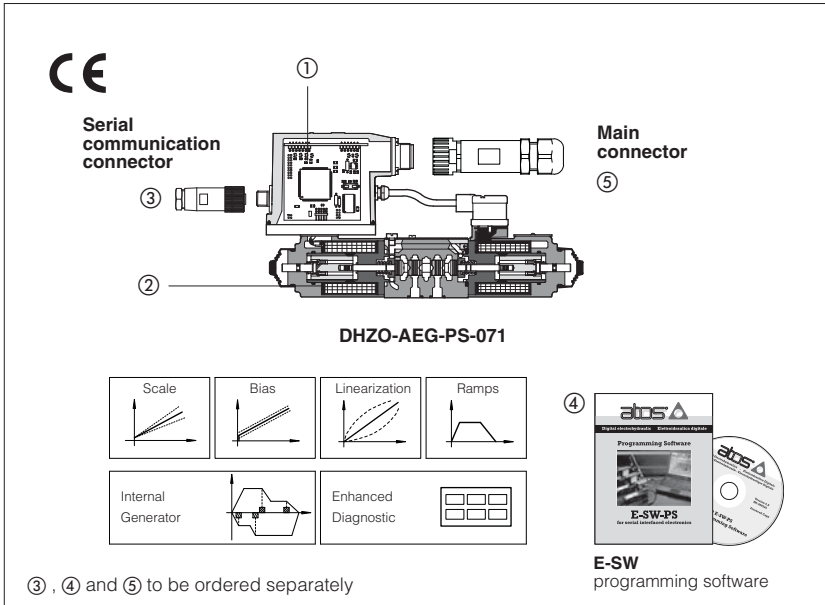

The driver ① supplies and controls the current to the solenoid of Atos proportional directional valves without transducer according to the internal reference signal. The solenoid ② proportionally transforms the current into a force, thus providing the valve hydraulic regulation. The directional valve controls the movement of the linear or rotative actuator to which it is connected. E-RI-AEG drivers - internally generates reference signal according to the state of the four ON-OFF inputs available on the main connector. The machine central unit handles the desired actuator motion cycle as a sequence of up to 16 different phases stored in the driver. For each phase it is possible to set speed and ramp. E-RI-AEZ controllers - automatically handles the actuator motion cycle as a sequence of up to six different phases. The actuator has to be equipped with an analog position transducer. The controller uses the actuator position feedback to activate the desired phase according to the position switch-over, set by software. Atos PC software ④ allows to program the driver/controller and update its firmware through serial communication interface.

## 1 MODEL CODE

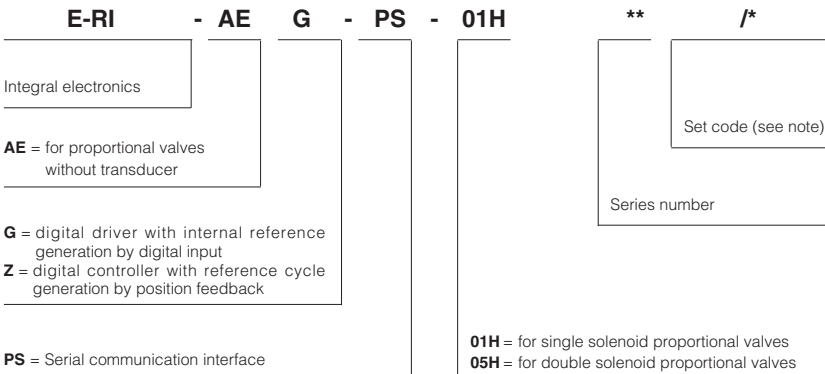

**Note:** the set code identifies the correspondance between the digital integral driver and the relevant valve; it is assigned by Atos when the driver is ordered as a spare part.

### Electrical Features:

- Functional parameters are factory preset for best performances
- Standard 12 pin main connector (5) for power supply, enable, fault, monitor and on-off inputs
- 5 pin connector (3) for serial communication interface
- 5 pin connector for external analog position transducer or potentiometer (for AEZ execution)
- Electrical protection against reverse polarity of power supply
- IP67 protection degree
- CE mark to EMC directive

### Software Features:

- Internal reference signal generation
- Setting of valve functional parameters: bias, scale, ramps, dither
- Linearization function for the hydraulic regulation
- Setting of valve dynamic response to optimize the application performances
- Complete diagnostics of driver/controller status, solenoid and fault conditions
- Intuitive graphic interface
- In field firmware update trough standard serial communication
- Internal oscilloscope function

## 2 INTERNAL GENERATION MODES

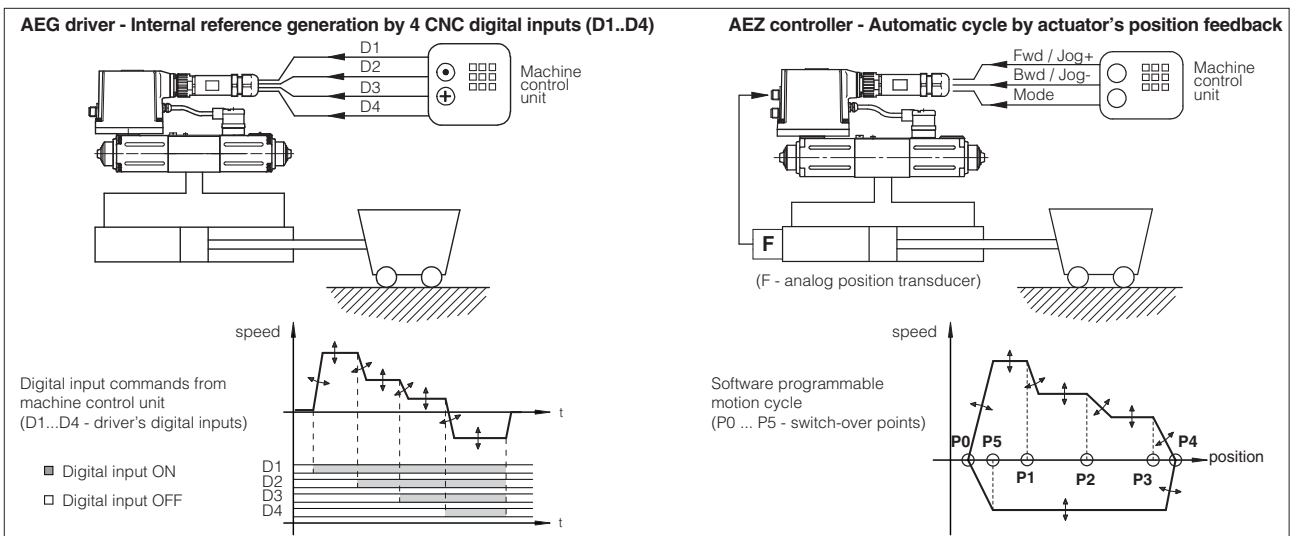

### 3 BLOCK DIAGRAM

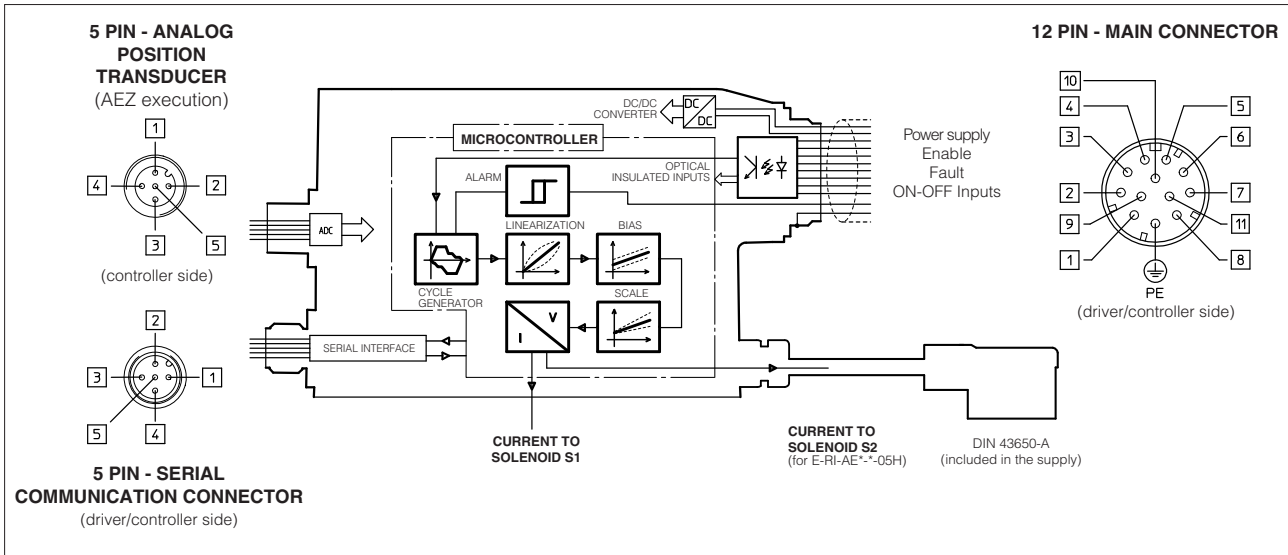

### 4 ELECTRONIC CONNECTIONS

#### 4.1 12 PIN MAIN CONNECTOR (AEG execution)

PIN	SIGNAL	TECHNICAL SPECIFICATIONS	NOTES
1	V+	Power supply 24 Vdc for solenoid power stage (see 5.1)	Input - power supply
2	V0	Power supply 0 Vdc for solenoid power stage (see 5.1)	Gnd - power supply
3	ENABLE	Enable (24 Vdc) or disable (0 Vdc) the driver (see 5.2)	Input - on/off signal
4	D1	Digital input referred to pin 2 (see 5.3)	Input - on/off signal
5	AGND	Ground - signal zero for MONITOR signal	Gnd - analog signal
6	MONITOR	Monitor analog output: $\pm 5$ Vdc maximum range (see 5.4)	Output - analog signal
7	D2	Digital input referred to pin 2 (see 5.3)	Input - on/off signal
8	NC	do not connect	
9	D3	Digital input referred to pin 2 (see 5.3)	Input - on/off signal
10	D4	Digital input referred to pin 2 (see 5.3)	Input - on/off signal
11	STATUS	Driver status : Fault or software selectable output (see 5.6)	Output - on/off signal
PE	EARTH	Internally connected to driver housing	

#### 4.2 12 PIN MAIN CONNECTOR (AEZ execution)

PIN	SIGNAL	TECHNICAL SPECIFICATIONS	NOTES
1	V+	Power supply 24 Vdc for solenoid power stage (see 5.1)	Input - power supply
2	V0	Power supply 0 Vdc for solenoid power stage (see 5.1)	Gnd - power supply
3	ENABLE	Enable (24 Vdc) or disable (0 Vdc) the controller (see 5.2)	Input - on/off signal
4	MODE	Jog or Homing mode selection (see 5.7)	Input - on/off signal
5	AGND	Ground - signal zero for MONITOR signal	Gnd - analog signal
6	MONITOR	Monitor analog output: $\pm 5$ Vdc maximum range (see 5.4)	Output - analog signal
7	NC	do not connect	
8	MONITOR2	2nd monitor analog output: $\pm 5$ Vdc maximum range (see 5.5)	Output - analog signal
9	FWD/JOG+	Start and stop forward cycle or Jog+ command (see 5.8)	Input - on/off signal
10	BWD/JOG-	Start and stop backward cycle or Jog- command (see 5.8)	Input - on/off signal
11	STATUS	Controller status : Fault or software selectable output (see 5.6)	Output - on/off signal
PE	EARTH	Internally connected to controller housing	

#### 4.3 ANALOG POSITION TRANSDUCER CONNECTOR - M12 - 5 PIN (only for AEZ execution)

PIN	SIGNAL	TECHNICAL SPECIFICATION	NOTES
1	VT	Remote transducer power supply 24 V <sub>dc</sub>	Output - power supply
2	TR	Remote transducer signal (see 5.9)	Input - analog signal
3	AGND	Analog ground	Gnd - analog signal
4	VTP+	Power supply reference + 5 V <sub>dc</sub> @ 10 mA output supply to pin 3 (AGND)	Output - reference analog
5	VTP-	Power supply reference - 5 V <sub>dc</sub> @ 10 mA output supply to pin 3 (AGND)	Output - reference analog

#### 4.4 SERIAL COMMUNICATION CONNECTOR - M12 - 5 PIN

PIN	SIGNAL	TECHNICAL SPECIFICATION	NOTES
1	NC	do not connect	
2	NC	do not connect	
3	RS_GND	Signal zero data line	Gnd - digital signal
4	RS_RX	Valves receiving data line	Input - digital signal
5	RS_TX	Valves transmitting data line	Output - digital signal

### 5 SIGNALS SPECIFICATIONS

Atos proportional valves are CE marked according to the applicable directives (e.g. Immunity/Emission EMC Directive).

Installation, wirings and start-up procedures must be performed according to the general prescriptions shown in table F003 and in the user manuals included in the E-SW programming software.

The electrical signals of the driver/controller (e.g. monitor signals) must not be directly used to activate safety functions, like to switch-ON/OFF the machine safety components, as prescribed by the European standards (Safety requirements of fluid technology systems and components-hydraulics, EN-982).

#### 5.1 Power supply and wirings (V+ and V0)

The power supply must be appropriately stabilized or rectified and filtered: apply at least a 10000  $\mu$ F/40 V capacitance to single phase rectifiers or a 4700  $\mu$ F/40 V capacitance to three phase rectifiers.

A safety fuse is required in series to each driver power supply: 2,5 A fuse.

#### 5.2 Enable Input Signal (ENABLE)

To enable the driver/controller, supply a 24 V<sub>dc</sub> on pin 3 referred to pin 2: Enable input signal allows to enable/disable the current supply to the solenoid, without removing the electrical power supply to the driver/controller; it is used to active the communication and the other driver/controller functions when the valve must be disabled for safety reasons. This condition does not comply with European Norms EN13849-1 (ex EN954-1).

#### 5.3 Digital Input Signals (D1, D2, D3, D4 - only for AEG execution)

The 4 ON-OFF input signals (D1...D4) are used to select the active reference signal, among the available stored values. They can be software configured to activate up to 4 (standard mode) or 16 (binary mode) different motion phases. The polarity of the digital inputs can be customized using the Atos PC programming software: active status = 24 V<sub>dc</sub> is the default setting.

#### 5.4 Monitor Output Signal (MONITOR)

The driver/controller generates an analog output signal (MONITOR) to monitor the actual valve coil current referred to AGND; the monitor output signal can be software set to show other signals available in the driver/controller (e.g. internal reference).

The output maximum range is  $\pm 5$  V<sub>dc</sub> : 0  $\div$  5 V<sub>dc</sub> for two position single solenoid valves and  $\pm 5$  V<sub>dc</sub> for double solenoid valves and three position single solenoid valves (see valve's tech. table).

#### 5.5 Actuator Monitor Signal (MONITOR2 - only for AEZ execution)

The controller generates a second analog output signal (MONITOR2) to monitor the actual position of the actuator referred to AGND; the monitor output signal can be software set to show other signals available in the controller (e.g. internal reference).

The output maximum range is  $\pm 5$ V<sub>dc</sub>; default settings is 0  $\div$  5 V<sub>dc</sub>.

#### 5.6 Status Output Signal (STATUS)

Status output signal indicates fault conditions of the driver/controller (short circuits, solenoid not connected, etc.) and it is not affected by Enable input signal status: fault presence corresponds to 0 V<sub>dc</sub>, normal working corresponds to 24 V<sub>dc</sub> (pin 11 referred to pin 2).

Status output signal can be also software configured to be active in specific motion cycle phase (see 6.6 and 6.7).

#### 5.7 Jog Mode or Homing Mode Selection Input Signal (MODE - only for AEZ execution)

The digital input MODE selects two control types.

Jog Mode: allows the user to manually manage the axis movements by 2 ON/OFF digital inputs (see 5.8) during startup operation, for emergency procedures or for maintenance purpose.

Homing Mode: allows the axis to move towards starting position (home).The Homing procedure is executed at system power on or if the axis actual position is outside of the admitted start tolerance threshold.

When 0V<sub>dc</sub> is supplied to MODE input, the internal generator is enabled and the controller can perform the programmed cycle.

See E-MAN-RI-AEZ manual for complete description of MODE activation procedure.

#### 5.8 Cycle generator Start/Stop or Jog commands (FWD/JOG+ and BWD/JOG- only for AEZ execution)

When the internal generator is selected (MODE input set to 0V<sub>dc</sub> - see 5.7) the inputs FWD/JOG+ and BWD/JOG- are used as start and stop command signal in order to manage to axis cycle. When Jog Mode is selected, the inputs FWD/JOG+ (forward) and BWD/JOG- (backward) are used to manually move the axis in both direction. To activate FWD/JOG+ or BWD/JOG- commands, provide 24V<sub>dc</sub> on pin 9 or pin 10 referred to pin 2.

Jog Mode set point is configurable by Atos programming software.

#### 5.9 Analog Position Transducer Input Signal (TR - only for AEZ execution)

Remote position transducer must be connected to the controller using the dedicated M12 connector (see 4.3). The input range is software selectable within 0 - 10 V<sub>dc</sub> or 0 - 20 mA maximum range; default setting is 0 - 10 V<sub>dc</sub>.

## 6 MAIN SOFTWARE PARAMETER SETTINGS

The following is a brief description of the main settings and features of E-RI-AEG drivers and E-RI-AEZ controllers.

For a detailed descriptions of available settings, wirings and installation procedures, please refer to the programming manual E-MAN-RI-AEG and E-MAN-RI-AEZ included in the E-SW-PS Dvd programming software (see section 9).

### 6.1 Scale

Scale function allows to set the maximum current supplied to the solenoid, corresponding to the max valve regulation, at maximum reference signal value.

This regulation allows to adapt the maximum current supplied from the driver to the specific nominal current of the proportional valves to which the driver is coupled; it is also useful to reduce the maximum valve regulation in front of maximum reference signal.

Two different Scale regulations are available for double solenoid valves: ScaleA for positive reference signal and ScaleB for negative reference signal.

### 6.2 Bias and Threshold

Proportional valves may be provided with a dead band in the hydraulic regulation corresponding to their switch-off status.

This dead band discontinuity in the valve regulation can be compensated by activating the Bias function, which adds a fixed preset Bias value to the reference signal (analog or fieldbus external input).

The Bias function is activated when the reference signal overcome the Threshold value, preset into the driver.

The Bias setting allows to calibrate the Bias current to the specific proportional valve to which the driver is coupled.

The Threshold setting is useful to avoid undesired valve regulation at zero reference signal when electric noise is present on the analog input signal: smaller threshold reduces the reference signal dead band, greater values are less affected by electric noise presence.

Two different Bias regulations are available for double solenoid valves: positive reference signals activate BiasA and negative reference signals activate BiasB.

Refer to the programming manuals for a detailed description of other software selectable Bias functions.

### 6.3 Offset

Proportional valves may be provided with zero overlapping in the hydraulic regulation corresponding to zero reference input signal (valve central spool position).

The Offset function allows to calibrate the Offset current, required to obtain valve spool central position, to the specific hydraulic system setup (e.g. valve applied to cylinder with differential areas).

### 6.4 Linearization

Linearization function allows to set the relation between the reference input signal and the controlled valve regulation.

Linearization is useful for applications where it is required to linearize the valve regulation in a defined working condition.

### 6.5 Variable Dither

The dither is the frequency modulation of the current supplied to the solenoid. To reduce the hysteresis should be selected a lower value of frequency, despite a lower regulation stability, because a small vibration in the valve regulating parts considerably reduces static friction effects.

To improve the regulation stability, should be selected a high value of frequency, despite a higher hysteresis. This solution in some application can lead to vibration and noise. Normally, the right setting is a compromise and depends on system setup.

E-RI-AEG drivers allow to realize a variable dither frequency that linearly depends on the demanded current: variable dither frequency allows an higher degree to optimize the valve hysteresis.

### 6.6 References generator - AEG driver

E-RI-AEG driver actuates up to 16 different phases (speed + ramps), according to the status of the 4 ON-OFF input signals available on the main connector.

The machine control unit can manage complex motion cycle by simply switching the reference signals, through 4 digital inputs (see 5.3).

For each phase Atos PC software allows to store internally the desired speed regulation (corresponding to the valve reference signal), ramp time and STATUS digital output level (see 5.6).

The digital inputs are also software configurable into 2 different reference selection mode:

- *Standard mode*  
each digital input corresponds to a different value; up to 4 different internal values are available
- *Binary mode*  
each digital input combination corresponds to a different value; up to 16 different internal values are available

### 6.1, 6.2 - Scale, Bias & Threshold

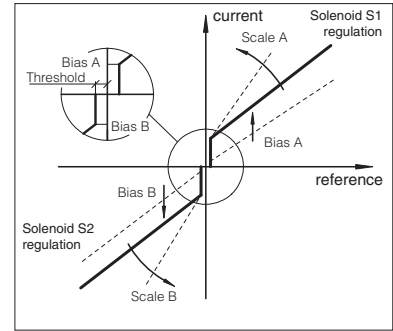

### 6.3 - Offset

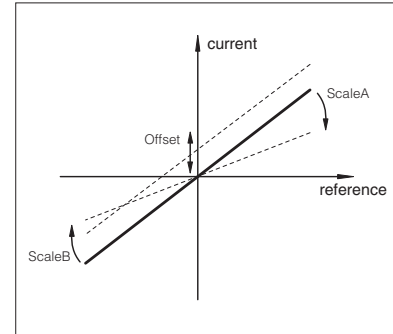

### 6.4 - Linearization

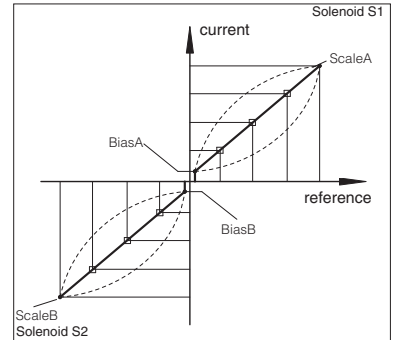

### 6.5 - Variable Dither

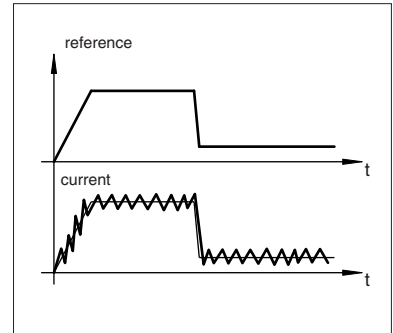

**Software features (see section 7 for example of cycle generation)**

- parameter setting for each phase:
  - speed regulation  $V_n$ : corresponding to the solenoid current and therefore to the valve regulation
  - ramp time  $R_n$ : time for a 0÷100% speed step ( $V_n - V_{n-1}$ )
  - status  $S_n$ : corresponding to the STATUS digital output level (see 5.6)
- parameter setting common for all digital inputs:
  - selection mode: as Standard Mode / Binary Mode
  - polarity: as Active High / Active Low
  - output mode: as standard Fault / Status signal
- diagnostic:
  - actual phase, showing the active phase during the cycle
  - inputs state, showing  $D1 \div D4$  electrical state (ON/OFF)

**6.7 Motion cycle generator - AEZ controller**

E-RI-AEZ controller automatically handles forward / backward motion cycles with fast-slow speed control according to the programmed cycle. The digital controller reads the actual cylinder position (see 5.9), and it actuates up to six different available motion phases for the forward cycle and up to six different available motion phases for the backward cycle. Atos PC software allows to program for each phase the desired actuator speed (corresponding to the valve reference signal), the ramp time, the switch-over position and the STATUS digital output level (see 5.6). The machine control unit set the commands through digital pin to actuate the pre-setted motion cycle, using FWD/JOG+ and BWD/JOG- commands. For maintenance or service purpose the controller could be set also in Jog Mode (see 5.7) to move manually the cylinder forward or backward by FWD/JOG+ and BWD/JOG- commands (see 5.8).

**Software features (see section 8 for example of cycle generation)**

- parameter setting for each phase:
  - speed regulation  $V_n$ : corresponding to the solenoid current and thus to the valve regulation
  - ramp time  $R_n$ : time for a 0÷100% speed step ( $V_n - V_{n-1}$ )
  - switch-over position  $P_n$ : corresponding to the cylinder position at which the driver will active the motion phase
  - status  $S_n$ : corresponding to the STATUS digital output level (see 5.6)
- parameter setting common for all digital input:
  - output mode: as Fault / Sequence
  - JOG speed  $V_J$ : corresponding to the speed used when Jog Mode is active
  - JOG RAMPs: time for a 0÷100% speed step used when Jog Mode is active
- diagnostic:
  - actual phase, showing the active phase during the cycle
  - cylinder position monitor (see 5.5)
  - switch-over position state

**7 AEG - EXAMPLE OF CYCLE GENERATION**

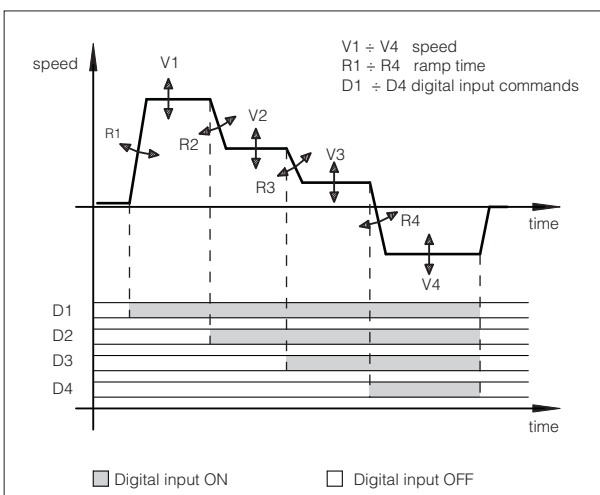

**8 AEZ - EXAMPLE OF CYCLE GENERATION**

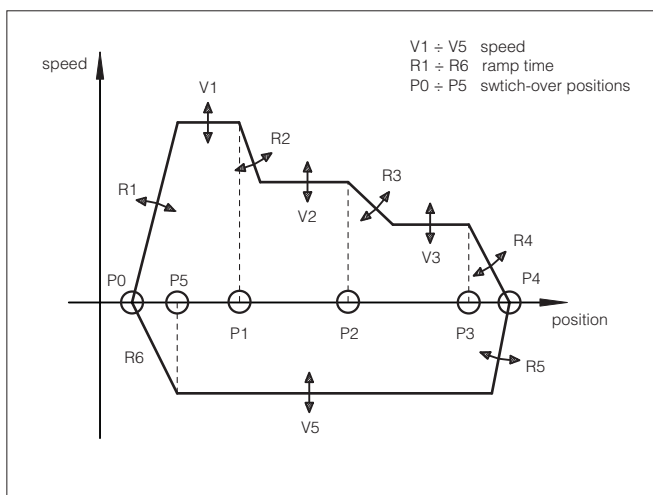

**9 SOFTWARE TOOLS**

The driver/controller configuration and parameters can be easily set with the Atos E-SW-PS programming software. For a more detailed description of software interface, PC requirements, adapters, cables and terminators, please refer to technical table G500.

**Programming software, must be ordered separately:**

- E-SW-PS** (mandatory - first supply) = Dvd including E-SW-\* software installer and operator manuals; it allows the registration to Atos digital service
- E-SW-PS-N** (optional - next supplies) = as above but not allowing the registration to Atos digital service.

On first supply of the E-SW-PS software, it is required to apply for the registration in the Atos download area : [www.download.atos.com](http://www.download.atos.com) .

Once the registration is completed, the password will be sent by email.

The software remains active for 10 days from the installation date and then it stops until the user inputs his password.

With the password you can also download, in your personal area, the latest releases of the Atos software, manuals, drivers and configuration files.

**USB Adapters, Cables and Terminators can be ordered separately (see tab. G500)**

**10 DRIVER/CONTROLLER CHARACTERISTICS**

Power supply (see 5.1)	Nominal: +24 V <sub>DC</sub> Rectified and filtered: V <sub>rms</sub> = 21 ÷ 32 V <sub>MAX</sub> (ripple max 10 % V <sub>FP</sub> )
Max power consumption	50 W
Enable input (see 5.2)	Range : 0 ÷ 9 V <sub>DC</sub> (OFF state), 15 ÷ 24 V <sub>DC</sub> (ON state), 9 ÷ 15 V <sub>DC</sub> (not accepted); Input impedance: R <sub>i</sub> > 37 kΩ
On-Off inputs (see 5.3)	Range : 0 ÷ 5 V <sub>DC</sub> (OFF state), 9 ÷ 24 V <sub>DC</sub> (ON state), 5 ÷ 9 V <sub>DC</sub> (not accepted); Input impedance: R <sub>i</sub> > 10 kΩ
Output supply	±5 V <sub>DC</sub> @ max 10 mA : output supply for external potentiometers ( <b>AEZ execution</b> )
Status output (see 5.6)	Output range :    0 ÷ 24 V <sub>DC</sub> (ON state ≅ [power supply] ; OFF state ≅ 0 V) @ max 50 mA
Alarms	Solenoid not connected/short circuit, overtemperature, under temperature
Format	Sealed box on the valve; IP67 protection degree
Operating temperature	-20 ÷ 60 °C (storage -20 ÷ 70 °C)
Mass	approx. 430 g
Additional characteristics	Short circuit protection of solenoid current supply; current control by P.I.D. with rapid solenoid switching
Electromagnetic compatibility (EMC)	According to Directive 2004/108/CE (Immunity: EN 61000-6-2; Emission: EN 61000-6-3)
Communication interface Physical Layer Protocol	serial RS232 Atos ASCII coding
Recommended wiring cable	LiYCY shielded cables:    0,5 mm <sup>2</sup> for length up to 40 m [1,5 mm <sup>2</sup> for power supply and solenoid]

**11 CHARACTERISTICS OF CONNECTORS - MAIN AND COMMUNICATION CONNECTOR (to be ordered separately)**

CODE	SP-ZH-12P	SP-ZH-5P	SP-ZH-5PM
Type	Female straight circular socket plug 12pin	Female straight circular socket plug 5 pin	Male straight circular socket plug 5 pin
Standard	DIN 43651	M12 – IEC 60947-5-2	M12 – IEC 60947-5-2
Material	Plastic reinforced with fiber glass	Plastic	Plastic
Cable gland	PG16	PG9	PG7
Cable	LiYY 10 x 0,14 mm <sup>2</sup> (signal) LiYY 3 x 1 mm <sup>2</sup> (power supply)	LiYCY 5x0,25 mm <sup>2</sup> shielded	diameter 4 ÷ 6 mm
Connection type	to crimp	screw terminal	screw terminal
Protection (DIN 40050)	IP 67	IP 67	IP 67

**12 OVERALL DIMENSIONS [mm]**

