

Hydraulic cylinders type **CNX** - stainless steel round heads with counterflanges to ISO 6020-1 - nominal pressure 10 MPa (100 bar) - max 15 MPa (150 bar)

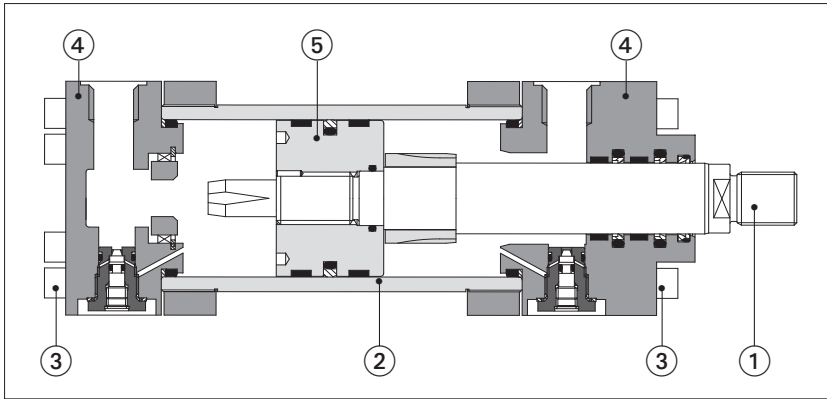

CNX cylinders are derived from standard CN (tab. B180) with stainless steel construction to withstand extreme and corrosive environmental conditions and to ensure compatibility with water based fluids or pure water.

They are ideally suited for a variety of applications and industries including: pharmaceutical, marine, military, waste management, offshore and chemical processing.

- Bore sizes from **50 to 100 mm**
- Strokes up to **3000 mm**
- Rods with rolled threads
- **9** standard mounting styles
- **3** seals options
- Rod guide rings for low wear
- Adjustable or fixed cushionings
- Optional built-in position transducer, **see tab. B310**

Stainless steel attachments are available on request, for dimensions **see tab. B500**.

For cylinder dimensions and options **see tab. B180**.

1 MATERIALS AND SPECIFICATIONS

Cylinder component	Material	Features
ROD ① and PISTON ⑤	AISI 431	High strenght and good corrosion resistance
HOUSING ② and HEADS ④	AISI 316L	Optimum corrosion resistance
SCREWS ③	AISI 316 A4	Optimum corrosion resistance and high strength

2 MODEL CODE

CNX	M	- 63 / 45 * 0500 - S	3 0 8 - A - B1E3X1Z3	**
<p>CYLINDER SERIES CNX dimensions to ISO 6020 - 1</p> <p>ROD POSITION TRANSDUCER see section 4</p> <p>F = magnetosonic M = magnetosonic programmable N = magnetostrictive P = potentiometric V = inductive</p> <p>BORE SIZE, see section 6 from 50 to 100 mm</p> <p>ROD DIAMETER, see section 6 from 36 to 70 mm</p> <p>STROKE (1) up to 3000 mm</p> <p>MOUNTING STYLE (1)</p> <table style="width: 100%; border: none;"> <tr> <td style="width: 50%; border: none;"> A = front round flange B = rear round flange D = fixed eye E = feet L = intermediate trunnion N = front square flange P = rear square flange S = fixed eye + spherical bearing X = basic execution </td> <td style="width: 50%; border: none;"> REF. ISO MF3 MF4 MP3 MS2 MT4 * MF1 MF2 MP5 - </td> </tr> </table> <p>* XV dimension must be indicated in the model code, see tab. B180</p>	A = front round flange B = rear round flange D = fixed eye E = feet L = intermediate trunnion N = front square flange P = rear square flange S = fixed eye + spherical bearing X = basic execution	REF. ISO MF3 MF4 MP3 MS2 MT4 * MF1 MF2 MP5 -	<p>HEADS' CONFIGURATION (1) (3)</p> <p>Oil ports positions B1 = front head X1 = rear head</p> <p>Cushioning adjustments positions, to be entered only if adjustable cushionings are selected E3 = front head* Z3 = rear head* * = enter E2 and Z2 for mounting style E</p> <p>OPTIONS (1) (3):</p> <p>Air bleeds A = front air bleed W = rear air bleed</p> <p>SEALING SYSTEM, see section 5</p> <p>3 = (FKM + PTFE) very low friction, high temperatures and water based fluids 5 = (NBR + PTFE) very low friction, high speeds and water based fluids 8 = (NBR + PTFE and POLYURETHANE) high static and dynamic sealing</p> <p>SPACER (1)</p> <p>0 = none 2 = 50 mm 4 = 100 mm 6 = 150 mm 8 = 200 mm</p> <p>CUSHIONINGS (1)</p> <p>0 = none Fast adjustable 1 = rear only 2 = front only 3 = front and rear</p> <p>Fast fixed 7 = rear only 8 = front only 9 = front and rear</p>	<p>Series number (2)</p>
A = front round flange B = rear round flange D = fixed eye E = feet L = intermediate trunnion N = front square flange P = rear square flange S = fixed eye + spherical bearing X = basic execution	REF. ISO MF3 MF4 MP3 MS2 MT4 * MF1 MF2 MP5 -			

Notes:

- (1) For details see **tab. B180**
- (2) For spare parts request always indicate the series number printed on the nameplate
- (3) To be entered in alphabetical order

3 STAINLESS STEEL PROPERTIES

CNX cylinders are manufactured with selected stainless steel to withstand extended exposure to aggressive environments, the table at side shows the compatibility of AISI 316L and AISI 431 with the main aggressive substances.

The rod is chromeplated: chrome thickness 0,020 mm; hardness 850-1150 HV.

The low strength of AISI 316L limits the max pressure to 150 bar; for heavy duty applications AISI 630 is recommended, contact our technical office.

Material	Cylinder component	Mechanical properties		Corrosion resistance (2)
		Rm min [MPa]	Rs min [MPa]	
AISI 316L	housing and heads	450	195	> 1200 h
AISI 316 A4 70	screws	700	450	> 1200 h
AISI 431	piston and rod	800	600	> 600 h
AISI 420	Spherical bearing of style S	700	500	< 100 h
AISI 630 (17-4 ph) (1)	housing and rod	860	724	> 1000 h

Note: (1) Available on request for heavy duty applications
(2) Corrosion resistance in neutral salt spray to ISO 9227 NSS

Corrosion index for AISI 316L and AISI 431

Substance	Corrosion index	
	AISI 316L	AISI 431
Marine atmospheres	very good	good
Salt water	good	sufficient
33% Acetic acid	excellent	limited
2% Muriatic acid	good	limited
70% Phosphoric acid	limited	limited
65% Nitric acid	good	good
2% Sulfuric acid	excellent	limited
20% Sulfuric acid	limited	limited

4 CNX WITH BUILT-IN POSITION TRANSDUCER

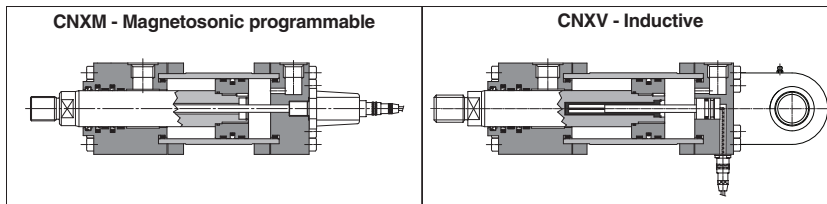

CNX cylinders are also available with magnetostrictive, potentiometric and inductive rod position transducers.

Stainless steel or aluminum materials used for transducers components make CNX servocylinders ideal for extreme working conditions as aggressive external environments or corrosive fluids.

For transducer performance and other details see **tab. B310**.

5 SEALING SYSTEM FEATURES

The sealing system must be chosen according to the working conditions of the system: speed, fluid type and temperature.

For HFA fluids or pure water it is recommended the use of proper additives to increase the sealing working life. Contact our technical office to check the compatibility with other fluids not mentioned below and specify type and composition.

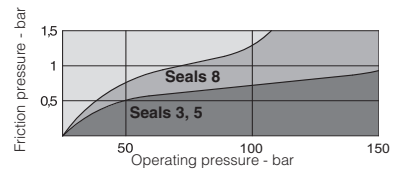

Sealing system	Material	Features	Max speed [m/s]	Fluid temperature range	Fluids compatibility	ISO Standards for seals	
						Piston	Rod
3	FKM + PTFE	very low friction and high temperatures	4	-20°C to 120°C	Mineral oils HH, HL, HLP, HLP-D, HM, HV fire resistance fluids HFA, HFB, HFD-U, HFD-R and water	ISO 7425/1	ISO 7425/2
5	NBR + PTFE	very low friction and high speeds	4	-20°C to 85°C	Mineral oils HH, HL, HLP, HLP-D, HM, HV, MIL-H-5606; fire resistance fluids HFA, HFC (water max 45%), HFD-U and water	ISO 7425/1	ISO 7425/2
8	NBR + PTFE + POLYURETHANE	high static and dynamic sealing	1	-20°C to 85°C	Mineral oils HH, HL, HLP, HLP-D, HM, HV	ISO 7425/1	ISO 7425/2

6 BORE / ROD SIZES

Ø Bore	50	63	80	100
Ø Rod	36	45	56	70

The table at side shows the available bore/rod sizes, see **tab. B180** for installation dimensions and options.

7 CYLINDER SECTION

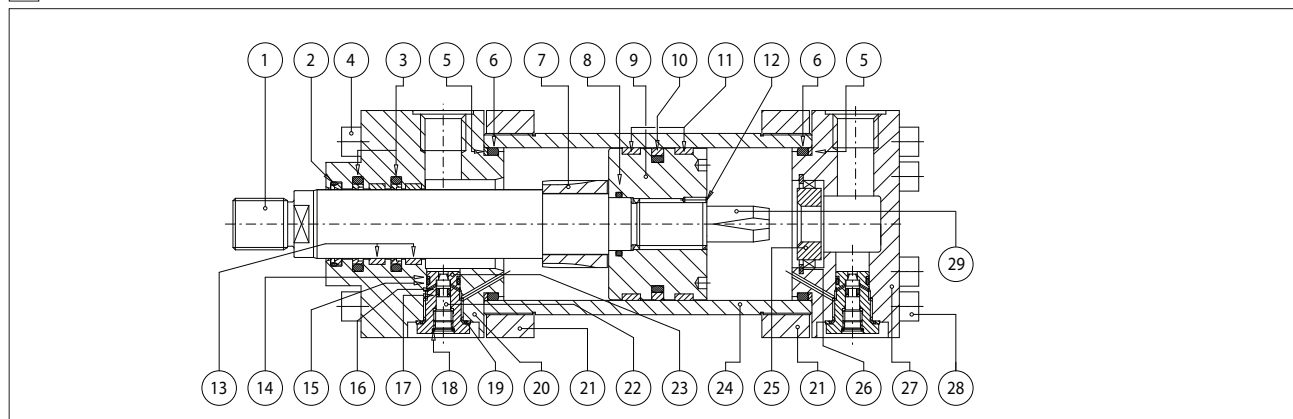

POS.	DESCRIPTION	MATERIAL	POS.	DESCRIPTION	MATERIAL	POS.	DESCRIPTION	MATERIAL
1	Rod	AISI 431 Chromeplated	11	Piston guide rings	PTFE	21	Counterflange	AISI 316L
2	Wiper	NBR / FKM and PTFE	12	Screw stop pin	AISI 304 / AISI 316L	22	Cushioning adjustment screw	AISI 316L
3	Rod seal	NBR / FKM and PTFE	13	Rod guide rings	PTFE	23	Cushioning adjustment plug	AISI 316L
4	Screw	AISI 316 A4	14	Anti-extrusion ring	PTFE	24	Cylinder housing	AISI 316L
5	Anti-extrusion ring	PTFE	15	O-ring	FKM	25	Rear cushioning sleeve	Bronze
6	O-ring	NBR / FKM	16	O-ring	FKM	26	Toroidal ring	AISI 304 / AISI 316L
7	Front cushioning piston	AISI 431	17	Anti-extrusion ring	PTFE	27	Rear head	AISI 316L
8	O-ring	NBR / FKM	18	Seeger	AISI 304 / AISI 316L	28	Screw	AISI 316 A4
9	Piston	AISI 431	19	Bonded seal	AISI 316 and FKM	29	Rear cushioning piston	AISI 431
10	Piston seal	NBR / FKM and PTFE	20	Front head	AISI 316L			